

2JC237G

SMA-Female Surface Mount Connector

Key Features

CELLULAR / LTE

SMA-Female

Surface Mount

Standard Polarity

Gold Plated

Dimensions 6.35 × 6.35 × 8.9 mm

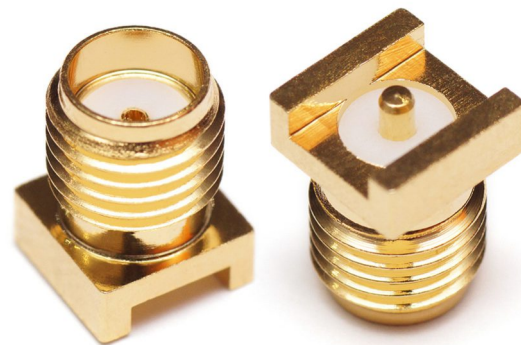

1. Electrical specifications

Parameters	2JC237G
Frequency (MHz)	DC – 7.125 GHz
Impedance (Ohm)	50
VSWR	1.3
Max. Input Power (W)	25

2. Mechanical and environmental specifications

Specifications	2JC237G
Mounting Type	Surface Mount Connector
Connector type	SMA
Connector Gender	Female (Jack)
Connector polarity	Standard polarity
Dimensions (mm)	6.35 × 6.35 × 8.9
Body Material	Brass
Body Plating	Gold
Contact Material	Brass
Contact Plating	Gold
Insulator Material	Teflon
Operating temperature	-40 °C to +85 °C
Storage Temperature	-40 °C to +85 °C
Substance Compliance	RoHS

3. PCB Layout

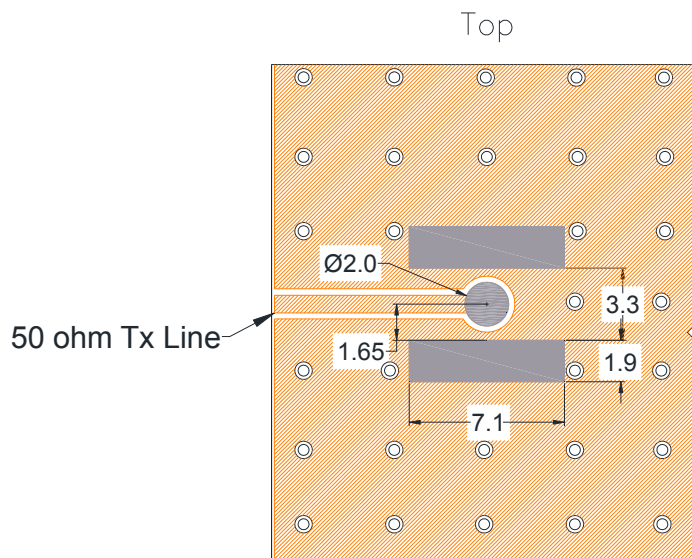

- Solder Region
- Copper Region
- Copper-Free Region

4. Packaging

PACKAGING SPECIFICATION

Connector	2JC237G
REEL	packed in antistatic bag
Max Quantity per Reel	500
CARTON	
Reels per Carton	10
Max Quantity per Carton	5000
Carton Dimensions (cm)	38 x 38 x 25
Carton Weight (Kg)	8.5

5. Tape and Reel Information

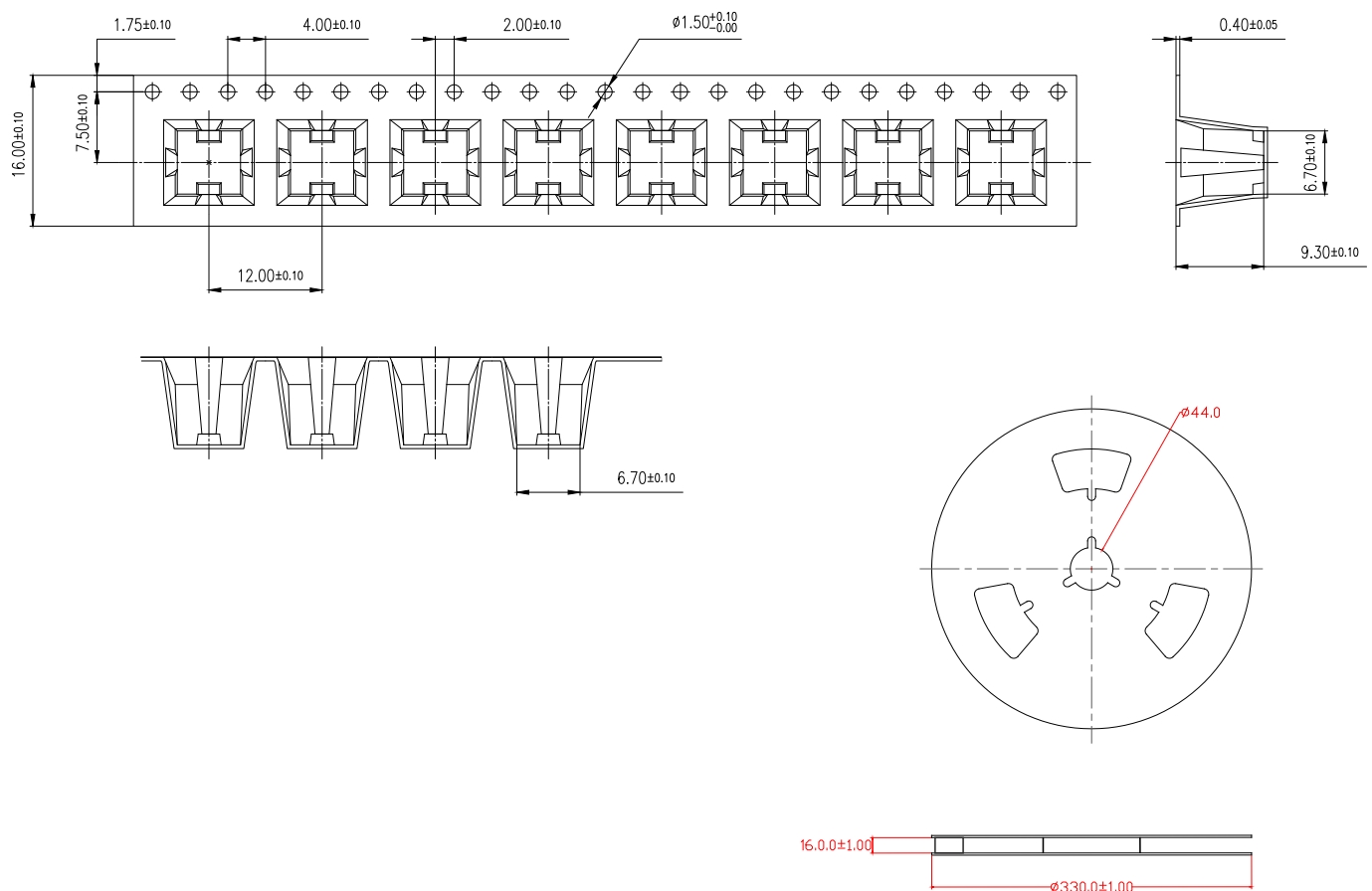

Tape and Reel Specifications

REFLOW TEMPERATURE PROFILE

Minimum Recommended Reflow Profile

	Method of heat transfer	Controlled hot air convection
1	Average temperature gradient in preheating	2.5 °C/s
2	Soak time	2-3 minutes
3	Max temperature gradient in reflow	3 °C/s
4	Time above 217 °C	Max 30 sec
5	Peak temperature in reflow	230 °C for 10 seconds
6	Temperature gradient in cooling	Max -5 °C/s

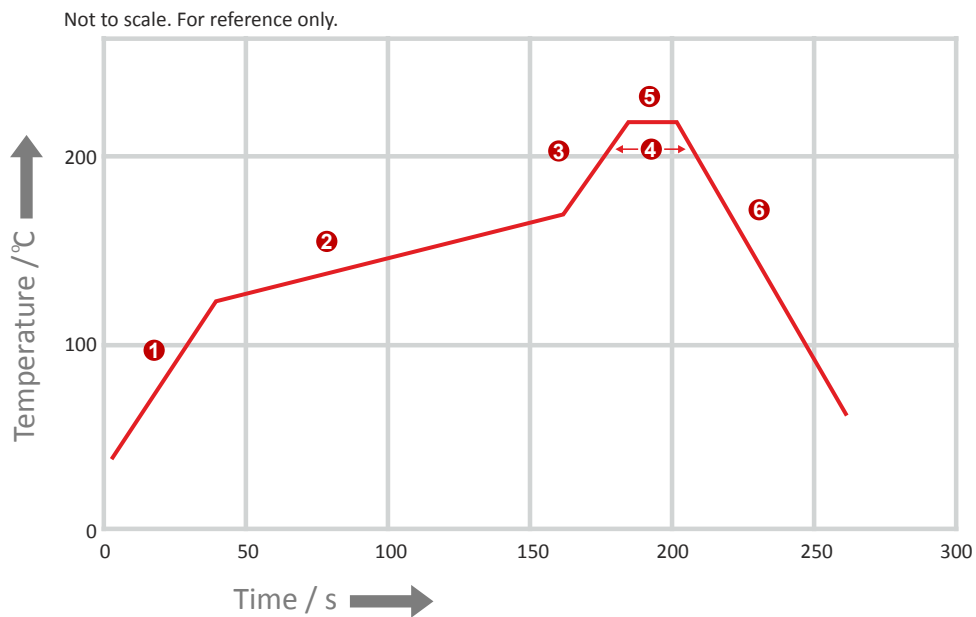

REFLOW TEMPERATURE PROFILE

Maximum Recommended Reflow Profile

	Method of heat transfer	Controlled hot air convection
1	Average temperature gradient in preheating	2.5 °C/s
2	Soak time	2-3 minutes
3	Max temperature gradient in reflow	3 °C/s
4	Time above 217 °C	Max 60 sec
5	Time above 230 °C	Max 50 sec
6	Time above 250 °C	Max 10 sec
7	Peak temperature in reflow	260 °C for 5 seconds
8	Temperature gradient in cooling	Max -5 °C/s

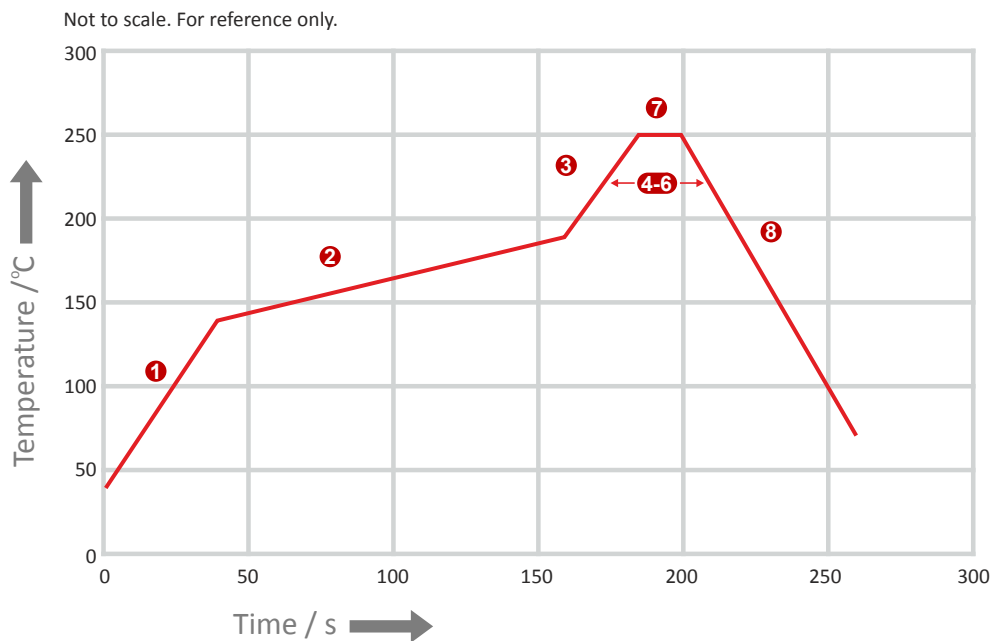

6. Connector drawings

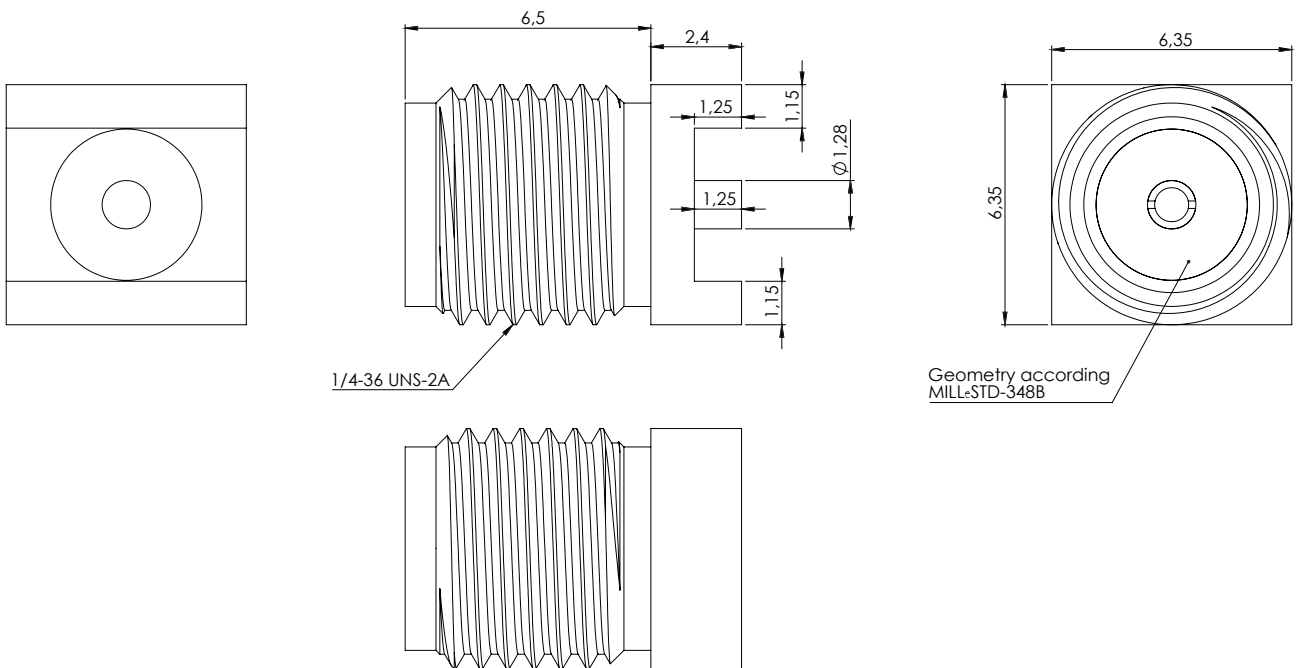

7. Connector Images

